



ISO 9001 FM584850

Feature

1. rising stem
2. union bonnet
3. comply to BS 5154
4. Working pressure PN16

12	Body	Bronze
11	Bolt	SS304
10	Disc washer	NBR
9	Disc holder	Brass
8	Stem	Brass
7	Gasket	PTFE
6	Union nut	Bronze 3/4"↓ Brass
5	Bonnet	Bronze 3/4"↓ Brass
4	Packing	PTFE
3	Packing ring	Brass
2	Packing gland	Brass
1	Handle wheel	Aluminum
No.	Part Name	Material

Option

1. SDNR type
2. PTFE disc washer

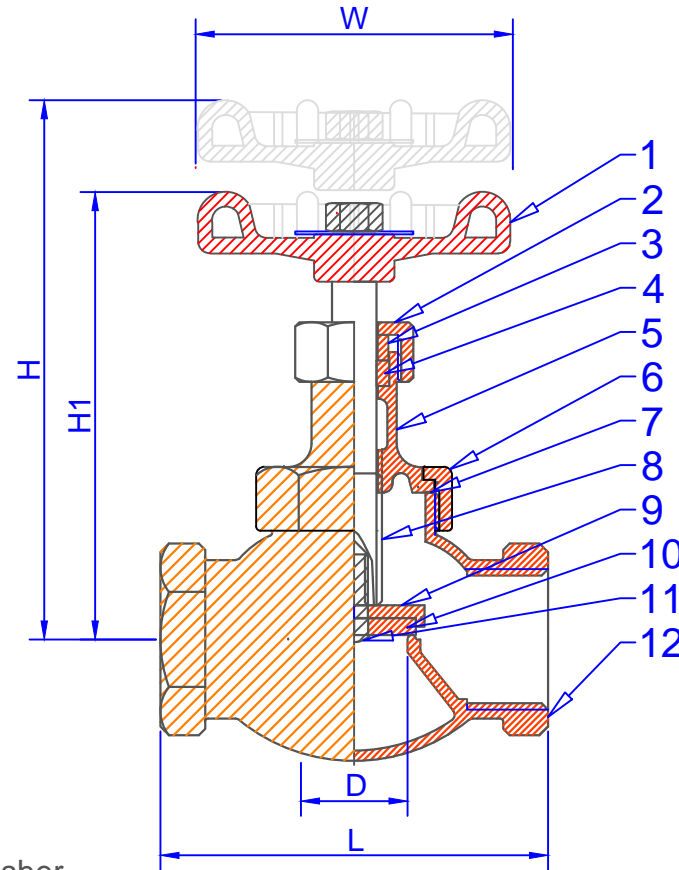

Fig. ST-308

Body Marking		
	DN25 PN16	

Test pressure (MSS SP-80)		
shell test	24	bar
seat test	18	
air test	6	



Dimensions

(mm)

Size	DN8	DN10	DN15	DN20	DN25	DN32	DN40	DN50	DN65	DN80	DN100
H			95	109	120	139	159	190			
H1			84	96	105	119	134	158			
L			65	75	91	105	120	145			
W			61	68	76	76	76	83			
D			15	20	25	32	40	50			