

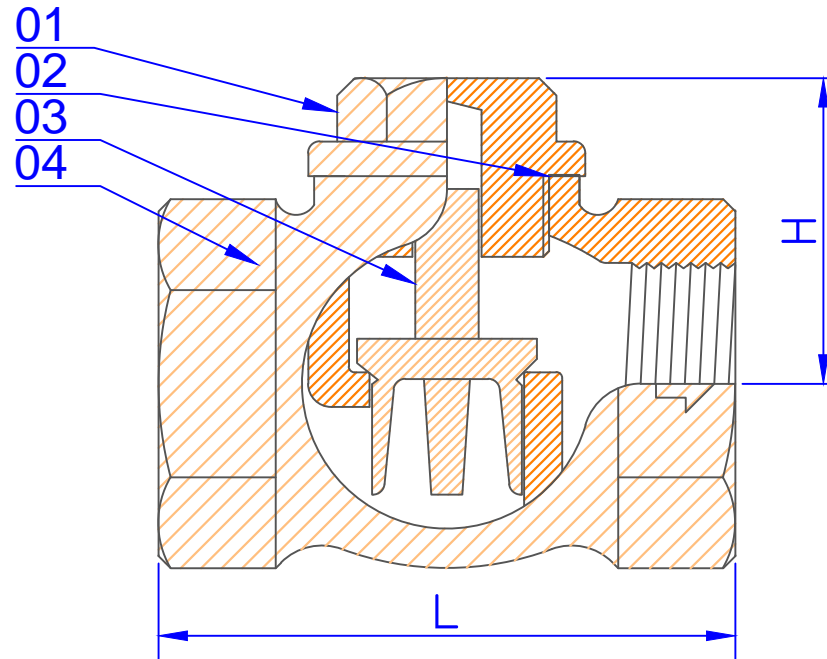

ISO 9001 FM584850

Feature

1. Lift type.
2. renewable disc



Test pressure		(MSS SP-80)
shell test	450	psi
seat test	330	
air test	80	

100 psi = 7Kg (7bar)



Fig. ST-402

Body Marking		
	2" WT300LBS	

Option 1:

- Fig.ST-402R for Rubber Disc washer
- Fig.ST-402O for O-ring Disc washer
- Fig.ST-402F for PTFE Disc washer

Option 2:

SS304 or Brass B159 spring

Dimensions

(mm)

Size	1/4"	3/8"	1/2"	3/4"	1"	1-1/4"	1-1/2"	2"	2-1/2"	3"	4"
H	27	28	28	29	38	45	48	56	91	92	125
L	45	45	50	57	65	75	85	100	120	137	153

4	Body	Bronze
3	Disc	Bronze
2	Gasket	PTFE or O-ring
		1-1/4" ↑ Bronze
1	Cap	1" ↓ Brass
No.	Part Name	Material