



ISO 9001 FM584850

Feature

1. flange ends conform to JIS B 2011 (version 2003)
2. non-rising stem
3. flange ends with groove
4. working pressure 5K (1Mpa)

Test pressure (MSS SP-80)		bar
shell test	7.5	
seat test	5.5	
air test	6	

100 psi = 7Kg (7bar)

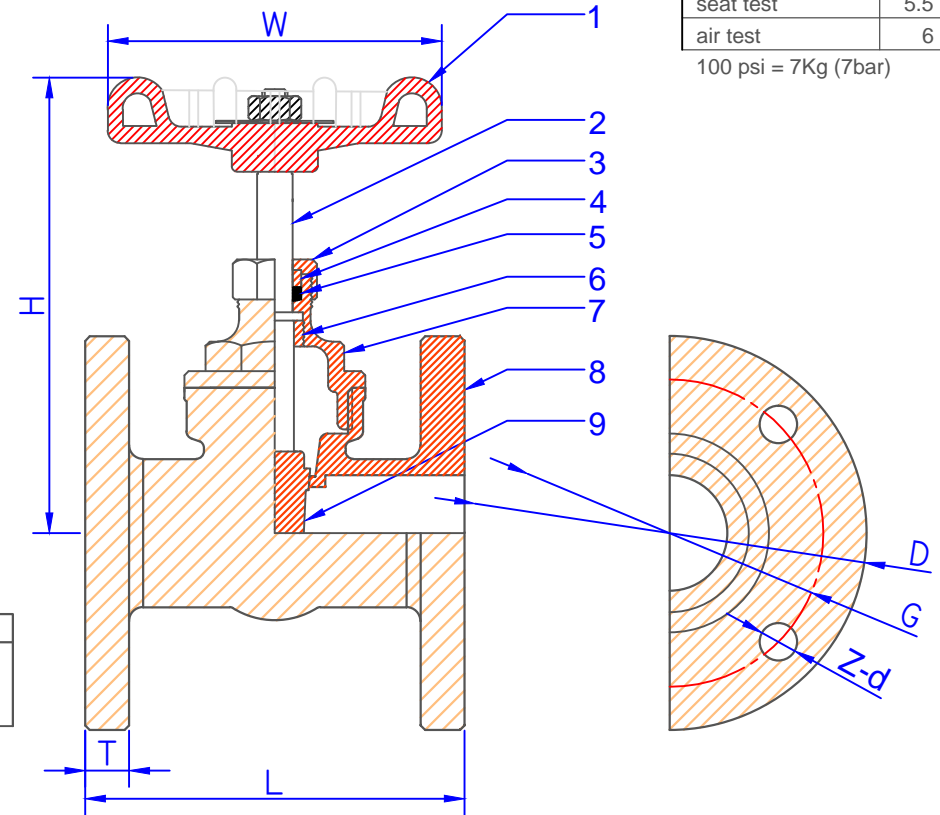

Fig. ST-803

Body Marking		
J	2"	5K

9	Disc	Brass
8	Body	Brass
7	Bonnet	Brass
6	Stem ring	Brass
5	Packing	PTFE
4	Packing ring	Brass
3	Packing gland	Brass
2	Stem	Brass
1	Handle wheel	Aluminum
No.	Part Name	Material

Dimensions

(mm)

Size			1/2"	3/4"	1"	1-1/4"	1-1/2"	2"	2-1/2"	3"	4"
H			85	94	105	125	140	155	200	220	270
L			80	80	80	100	100	115	127	142	165
W			54	61	61	77	77	83	105	112	132
T			9	10	10	12	12	14	14	14	16
D			80	85	95	115	120	130	155	180	200
G			60	65	75	90	95	105	130	145	165
Z-d			12-4	12-4	12-4	15-4	15-4	15-4	15-4	19-4	19-8