

## Feature

1. rising stem
2. screwed in bonnet
3. 150psi saturated steam to 185 °C or 365 °F
4. working pressure 20bar
5. comply to BS5154B

Connect ends comply to  
 B.1.20.1 (NPT)  
 BS21.0 (BSPT)  
 ISO-7 (Rc, Rp)

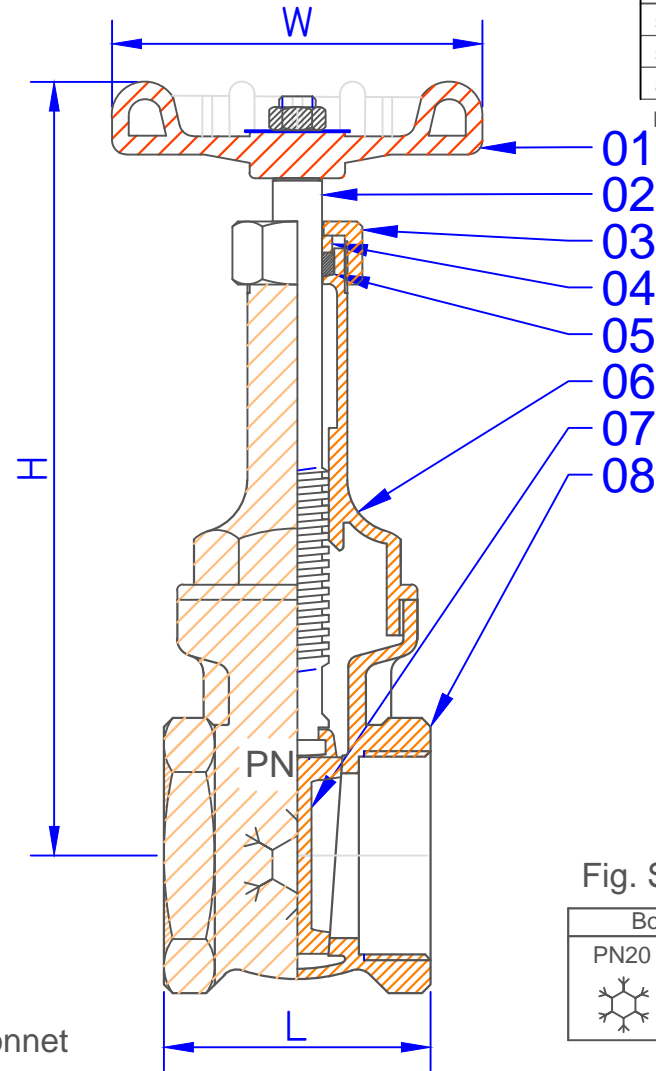
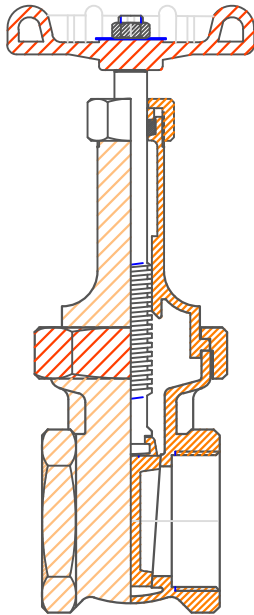

Test pressure (MSS SP-80)		bar
shell test	30	
seat test	22	
air test	6	

ISO 9001 FM584850



Fig. SW-205U for union bonnet

Fig. SW-205

Body Marking		
PN20	25mm	

8	Body	Bronze
7	Disc	Bronze
6	Bonnet	Bronze
5	Packing	PTFE
4	Packing ring	Brass
3	Packing gland	Brass
2	Stem	Brass
1	Handle wheel	Aluminum
No.	Part Name	Material

## Dimensions

(mm)

Size	8mm	10mm	15mm	20mm	25mm	32mm	40mm	50mm	65mm	80mm	100mm
H			102	120	150	164	190	245			
L			47	51	57	61	67	74			
W			54	61	77	77	83	105			